

DESIGN OF THE NEW FIRE STOPPER FOR EXTINGUISHING FIRE IN THE MINE GAS PIPELINES

¹Minieiev S., ¹Antonchik V., ²Yanzhula O., ³Chorny A., ⁴Makarenko R.,
⁵Belousov O., ⁶Livak O.

¹M.S. Poliakov Institute of Geotechnical Mechanics of the National Academy of Sciences of Ukraine

²Limited Liability Company «METINVESTKHOLDING»

³Central Headquarters of the SPMRS of Ukraine

⁴Mine Administration Herojev of Space Mine Management

⁵“Pershotravensky” mine management DTEK “Pavlogradvugillya”

⁶Ukrainian State University of Science and Technologies

Abstract. The article deals with the issues of occurrence, spread and extinguishing of fires in the mine gas pipelines for the methane removal during degassing of the coal massif and overlying rock layers. The composition of the gas mixture in the gas pipeline, various causes of ignition of gases in the gas pipelines, and specifics of methods for extinguishing fires in mine gas pipelines are considered. Devices which are mounted in various gas pipelines for extinguishing explosions and fires are analyzed. The main drawbacks of these devices are described. Recommendations are made for the ways to improve these devices.

The purpose of the research was to develop such a device for extinguishing fires in mine gas pipelines - a fire stopper of the mine gas pipeline - which is guaranteed to extinguish the flame front moving in the gas pipeline regardless of speed and direction of its movement.

The basis for improving the fire stopper for the mine gas pipeline was the task to create such obstacles which guarantee the extinguishing of the flame front in the gas pipeline by not only dividing it into separate flows and passing through narrow channels, but also by changing the direction of the gas flow by passing it through a labyrinth of narrow channels with a two-stage trap without increasing the gas-dynamic resistance of the device during its operation in the usual mode of pumping gas by vacuum pumps. The device should have small dimensions providing the possibility of its easy installation in the mine or on the surface, and it should be equally effective for extinguishing the flame moving both from the surface and in the mine gas pipelines.

The new technical solution in the design of the fire stopper is proposed. The sketch project of the new design of the fire stopper is shown. A description of its design and operation is provided. The advantages of the new fire stopper design are presented.

This fire stopper designed for the mine gas pipelines has small dimensions and weight, does not require additional equipment for maintenance and can be installed in any part of the gas pipeline, both in the mine workings and on the surface. This fire stopper can extinguish the flame front in both directions and provides little aerodynamic resistance to the movement of the gas flow.

Keywords: coal mine, degassing pipeline, flame front extinguishing, explosions, fire stopper, air inflows, methane concentration.

1. Introduction

Today, the live problem is fires occurred in mine workings during coal mining operations. It is known that one of the causes of fires in mine workings is occurrence of fires in mine gas pipelines for methane removal, which consists in the fact that fires in gas pipelines can occur both in mine workings and on the surface in the locations where mine gas is burned. The most dangerous fires are those that start on the surface in gas-fired boilers, where gas withdrawn from the mine is burned, when due to the low speed of gas movement in the gas pipeline, the combustion front begins to move through the gas pipeline against the movement of the gas mixture. This occurs when the speed of the combustion front exceeds the speed of gas mixture supply through the pipeline to the gas burner. The complexity of this situation is that, firstly, the amount of gas removed by vacuum pumps is small, and secondly, the



composition of the gas, which can consist, to a greater extent, of methane, oxygen, carbon dioxide, carbon monoxide, hydrogen, ethane, propane, butane and other substances, and can vary depending on several factors, such as gas capacity of the formations, location of the wells and geology of the formations (for example, there is a great accumulation of gas in places where the formations are disturbed), and composition of the gas mixture, which depends on both the coal formations and the number of cracks in them through which a significant amount of air is drawn in [1–3]. The speed of the combustion front depends on the composition of the gas mixture in which it moves; therefore, it is difficult to prevent the spread of fire by increasing the gas supply speed guaranteed for all compositions; besides, it requires considerable costs. It should also be borne in mind that depending on the wear of the mine gas pipeline, the concentration of indicator gases in it can change considerably due to various types of leaks and suction [2, 4]. At the same time, each ratio of the methane-air mixture (MAM) corresponds to its own speed of combustion and movement of the flame front in the gas pipeline. Fires can also occur for other reasons, for example, electric discharge or lightning striking the pipeline on the surface. In this case, the speed of the combustion front will be measured in hundreds of meters per second and will move against the flow of gas into the mine workings, which will lead to a large-scale accident.

Fires in gas pipelines can also occur in mine workings in compressor stations and vacuum pumps due to friction and heating of some pump parts or a spark between them. Such a fire can also quickly spread to all gas pipelines and lead to a great-scale accident in the mines [1, 2]. To prevent fires in gas pipelines, both in the mine and on the surface, fire stoppers are installed in the places of possible fire in the methane supply pipeline, which will stop the movement of the combustion front in its own volume.

Fire stoppers used for extinguishing flames in gas pipelines are of various types, in particular, plug-in, plate, spiral-tape, and others [3]. They have the following characteristic features.

Thus, plug-in fire stopper consists of a housing, in which porcelain balls with a diameter of 6 mm are located between two walls of a metal mesh (it is one of the options). The plug-in fire stopper is hermetically inserted into the gas pipeline in the proper place and the gas pumped from the coal seams moves through it. In the event of a gas explosion in the mine working, the combustion front, which moves through the gas pipeline, enters the plug-in fire stopper where it collapses on the obstacle in the form of the balls.

The well-known plate fire stoppers consist of a housing in which metal plates are fixed with gaps between them through which gas moves in normal mode of operation of the gas pipeline.

The spiral-tape fire stoppers, the "Blowback Protector" [5] in particular, are also well known; they consist of a housing in which a flame extinguishing device is fixed in the form of a roll of two twisted tapes - corrugated tape and ordinary tape. In the normal mode of the gas pipeline operation, gas from the pipe flows through the channels formed by the corrugations of the corrugated tape and then returns to the gas pipeline. In the event of an explosion, the combustion front of the shock wave

moving in the gas pipeline enters the narrow channels created by the corrugations of the corrugated tape, where it collapses and extinguishes due to heat loss and the division of the flame front into separate flame seats.

However, all these fire stoppers have some disadvantages. Thus, the disadvantages of plug-in fire stoppers are their large size and significant gas-dynamic resistance to the movement of gas between the balls when it moves through the gas pipeline in the usual mode of pumping gas by vacuum pumps. While disadvantages of the plate fire stoppers are their considerable dimensions, a lot of non-ferrous metal from which the plates are made, as well as the possibility of flame penetrating through the gaps between the plates in some cases [3, 4]. The spiral-tape fire stoppers, the "Blowback Protector" [5] in particular, have a significant gas-dynamic resistance during the movement of gas in the long channels formed by corrugations in the usual mode of pumping out gas by vacuum pumps, and, besides, there is a probability of the flame escaping through the straight (although narrow) channels.

There are some other known fire stoppers [6–8], but they also feature essential disadvantages in their designs, among which are significant gas-dynamic resistance to the movement of gas in the normal mode of operation of the gas pipeline, considerable dimensions, and short path for extinguishing the flame front of the shock wave, which can lead to the flame passing into the outlet pipe and further into the gas pipeline.

Thus, the existing designs of gas-pipeline fire stoppers are not efficient enough. Therefore, it is quite obvious that it is necessary to conduct additional research and to develop more effective designs of the fire stoppers. The fire stopper should have small dimensions and weight, should not create additional aerodynamic resistance to the flow of mine gas and should not require complex maintenance.

The purpose of the research was to design such a device for extinguishing fires in mine pipelines - a fire stopper of the mine gas pipeline - which guarantees extinguishing of the flame front moving in the gas pipeline regardless of speed and direction of its movement.

2. Methods

The basis for improving the fire stopper of the mine gas pipeline was the task to create such obstacles which guarantee the extinguishing of the flame front in the pipeline by not only dividing it into separate flows and passing through narrow channels, but also by changing the direction of the gas flow by passing it through a labyrinth of narrow channels with a two-stage trap without increasing the gas-dynamic resistance of the device during its operation in usual mode of pumping out gas by vacuum pumps. The device should be small in size with the possibility of being easy installed in the mine or on the surface, and should be equally effective for extinguish the flame which moves from the surface or in the mine pipelines.

3. Results and discussion

As a result of the conducted research and analysis of the parameters of the above-described designs of fire stoppers, the authors developed a new design which, to a considerable extent, took into account the mentioned disadvantages and structural drawbacks. The design is protected by a patent. This new design of the fire stopper is shown in Figures 1–4.

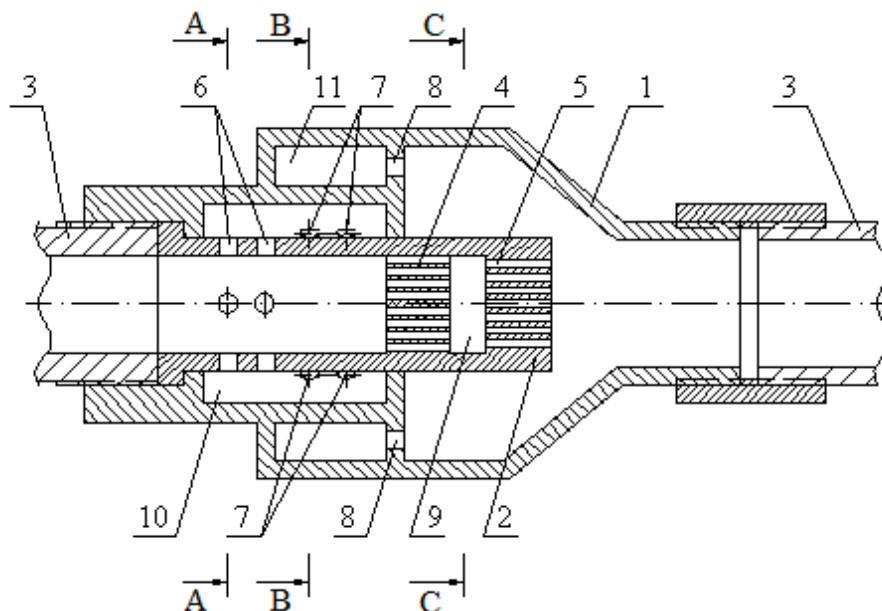

1 – housing; 2 – insert; 3 – mine gas pipeline; 4 – channels of the first block; 5 – channels of the second block; 6 – radial openings of the insert; 7 – radial openings of the housing; 8 – end openings of the housing; 9 – insert cavity; 10 – inlet cavity; 11 – housing cavity

Figure 1 – General view of the fire stopper of the mine gas pipeline in longitudinal section

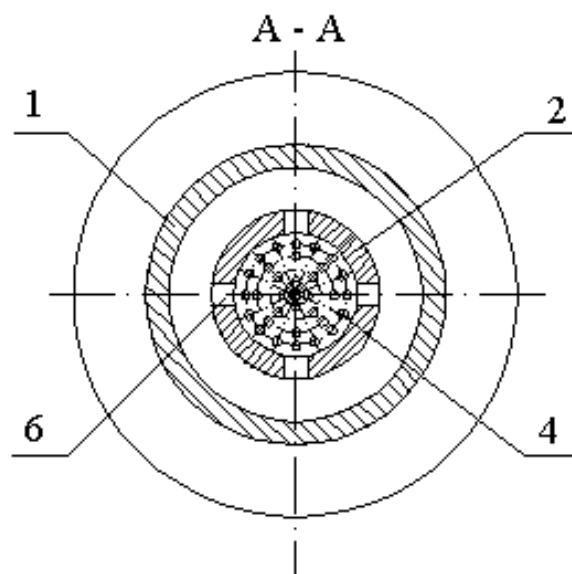

1 – housing; 2 – insert; 4 – channels of the first block; 6 – radial openings

Figure 2 – Cross-section A – A of the mine gas pipeline fire stopper

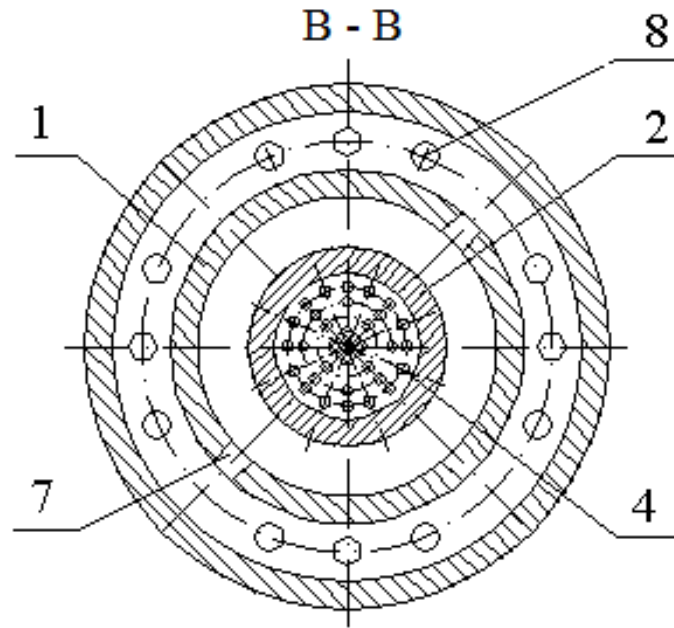

1 – housing; 2 – insert; 4 – channels of the first block; 7 – radial openings of the housing;
8 – end openings of the housing

Figure 3 – The illustrated cross-section B – B of the mine gas pipeline fire stopper

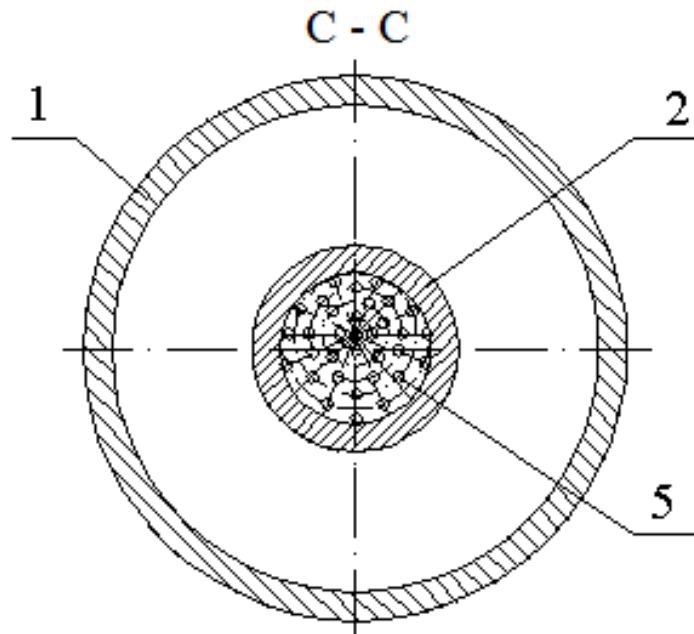

1 – housing; 2 – insert; 5 – channels of the second unit

Figure 4 – The illustrated cross-section C – C of the mine gas pipeline fire stopper

The fire stopper of the mine gas pipeline shown in fig. 1–4 consists of a housing 1, an insert 2 in the form of a hollow cylinder with an insert cavity 9, channels of the first block 4, channels of the second block 5, and radial openings of the insert 6,

which is inserted into the housing 1 and fixed in it by a thread on the mine gas pipeline 3. Housing 1 has radial openings of the housing 7, end openings of the housing 8, inlet cavity 10 and housing cavity 11.

The insert 2 is designed with the block with a great number of long straight channels of small diameter (channels of the second block 5), which are separated from the channels of the first block 4 by the insert cavity 9. The channels of the blocks are arranged so that their projections on the plane of the cavity walls do not overlap, which ensures the extinguishing of the flame front of the explosive wave in the gas pipeline in the following way. It is known that when a flame front of the explosive wave simultaneously passes through a great number of long straight channels of small diameter, it leads to its destruction and extinguishing due to heat loss on the walls of the channels and dividing of the flame front into its separate flame seats. But very long channels, which can fully guarantee the extinguishing of the flame front of the explosive wave, essentially increase dimensions and weight of the fire stopper of the mine gas pipeline, hence, creating difficulties for its use in mine conditions. In the case of the second block installed in the insert with a great number of long straight channels of small diameter, which are separated from the first block of channels by a cavity, and the channels of the blocks are located in such a way that their projections on the plane of the cavity walls do not overlap, the separate seats of the flame front of the explosive wave, which come out from the channels of the first block, collide in the cavity with the walls of the second block and, bouncing off them, mix in this cavity. The movement of the explosive wave and the flame front in the direction of the central axis of symmetry of the gas pipeline completely stops at the wall of the second block, after which the gas flow turns twice by 90° and enter the channels of the second block 5. It is important to note that with this method of extinguishing the flame front of the explosive wave, the length of the channels of the first and the second blocks can be much shorter than in other known devices. Therefore, the presence in the insert of the second block with a great number of long straight channels of small diameter, which are separated from the first block of channels by a cavity, and the channels of the blocks being located so that their projections on the plane of the cavity walls do not overlap, ensures the extinguishing of the flame front of the explosive wave in the gas pipeline by the fire stopper significantly smaller in size and weight. In the normal mode of operation of the gas pipeline, this design of the insert makes it possible to reduce the gas-dynamic resistance to the movement of gas in the gas pipeline in comparison with other known devices of the same purpose.

The fact that the fire stopper of the mine gas pipeline is equipped with two ring stages of cylindrical cavities, the inlet cavity 10 and the housing cavity 11, in the walls of which there are radial openings of the housing 7 and end openings of the housing 8, the projections of which on the walls of the cavities 10 and 11 do not overlap in the radial direction, and the openings on the wall of the first stage are located opposite the walls in the gaps between the openings on the wall of the second stage and the openings on the end wall of the housing are located in the same way, and the openings in the cylindrical walls are shifted in the axial direction so that their

projections on the walls create two separate groups of openings with some distance between them, makes it possible to reduce the gas-dynamic resistance to the movement of gas in the gas pipeline and to prevent spread of the flame front of the explosive wave in the following way. It is known that openings, in comparison with the channels of the same diameter, have a much lower gas dynamic resistance, therefore, in the normal mode of operation of the gas pipeline, the main volume of gas flows through the openings in the two ring stages of the cylindrical cavities 10, 11 of the fire stopper of the mine gas pipeline and a much smaller part of the volume of gas flows through the channels 4, 5 of the inserts. In the event of an accident, the flame front of the explosive wave moving at a speed of about 700 m/s passes through the straight section (in the form of a pipe) of the insert and gets into a trap of blocks 4, 5 with a great number of long straight channels of small diameter with a cavity 9 between them where it goes out completely. But when passing by the openings of the ring stages of the cylindrical cavities, the flame can pass into these openings. To prevent the flame from spreading through the openings of the ring stages of the cylindrical cavities, the openings are offset relative to each other in both radial and axial directions. This prevents the straight movement of the flame, leads to its stopping on the walls of the cavities, mixing with a significant amount of gas in these cavities, reducing the temperature of the flame, hence, leading to its extinguishing. In this way, the fire stopper of the mine gas pipeline makes it possible, on the one hand, to pass gas with negligible gas-dynamic resistance through the openings of the ring stages of cylindrical cavities, and, on the other hand, in the event of an accident, to extinguish the flame front of the explosive wave moving through the gas pipeline in the trap made of blocks with a great number of long straight channels of small diameter with a cavity between them through which the gas also flows and into which the flame front of the explosive wave enters.

The fire stopper of the mine gas pipeline will work in the following way. The housing 1 of the fire stopper is rigidly and hermetically mounted in the mine gas pipeline 3; the insert 2 is installed in the housing along its central axis of symmetry (see Fig. 1). During the operation of the fire stopper in normal mode, the main volume of gas, which is pumped out of the coal seams by vacuum pumps, flows through the radial openings of the insert 6, the radial openings of the housing 7 and the end openings of the housing 8 and, further, through the internal volume of the housing 1 into the gas pipeline 3; while a much smaller part of the gas volume flows through the channels of the first block 4, the cavity of the insert 9 and the channels of the second block 5 (Fig. 1–4). This design of the fire stopper does not create significant gas-dynamic resistance and ensures effective pumping out of gas by vacuum pumps. In the event of an accident, if a flame front of an explosive wave appears in the gas pipeline, it passes through the straight (pipe-like) section of the insert 2 and gets into the trap with a great number of long, straight, narrow channels of the first block 4 and channels of the second block 5 with the cavity of the insert 9 between them where it completely extinguishes (see Fig. 1).

This fire stopper for the mine gas pipelines, developed by the authors, has small dimensions and weight, does not require additional equipment for

maintenance, and can be installed in any part of the gas pipeline, both in mine workings and on the surface. This fire stopper can extinguish the flame front in both directions and provides little aerodynamic resistance to the movement of the gas flow.

4. Conclusions

Therefore, the proposed design of the fire stopper of the mine gas pipeline will guarantee, on the one hand, extinguishing of the flame front in both directions, and, on the other hand, provide negligible aerodynamic resistance to the movement of the gas flow. This fire stopper of the mine gas pipeline has relatively small dimensions and weight, does not require additional equipment and can be installed in any part of the gas pipeline, both in mine workings and on the surface.

REFERENCES

1. Minieiev, S.P., Rubinskij, A.A., Vitushko, O.V. and Radchenko, A.G. (2010), *Gornye raboty v slozhnykh usloviyakh na vybrosopasnyhugolnykh plastah* [Mining operations in difficult conditions at emission hazardous coal seams], Shidniy vidavnychiy dim, Donetsk, Ukraine.
2. Bulat, A.F., Minieiev, S.P., Smolanov, S.N. and Belikov, I.B. (2021), *Pozhary v gornykh vyrabotkakh. Izolyaciya avariynykh uchastkov* [Fires in mine workings. Isolation of emergency sections], V dele, Kharkiv, Ukraine.
3. Kudinov, D.V. (2006), *Sovershenstvovanie vzryvozashity shahtnyhm degazacionnykh system* [Improvement of explosion protection of mine degassing systems], Donbas, Donetsk, Ukraine.
4. Minieiev, S.P., Novikov, L.A., Lyutij, M.O. and Makarenko, R.V. (2022), "Influence of gas degassing pipeline tightness on air inflow and methane concentration", *Naukoviy visnik Donetskogo natsionalnogo universitetu*, no. 1(8)–2(9), pp.86–93. [https://www.doi.org/10.31474/2415-7902-2022-1\(8\)-2\(9\)-86-93](https://www.doi.org/10.31474/2415-7902-2022-1(8)-2(9)-86-93).
5. Salamandra, G.D., Vencel, N.M. and Zelenkov, A.A. (1973), *Ognepregraditel* [Fire barrier], SU, Pat. № 369913.
6. Kudinov, Yu.V., Kasimov, I.O. and Inyushin, B.A. (1986), *Ognepregraditel* [Fire barrier], SU, Pat. № 1266550.

About the authors

Minieiev Serhii, Doctor of Technical Sciences (D.Sc.), Professor, Head of Department of Pressure Dynamics Control in Rocks, M.S. Poliakov Institute of Geotechnical Mechanics of the National Academy of Sciences of Ukraine (IGTM of the NAS of Ukraine), Dnipro, Ukraine, serqmineeiv@gmail.com, **ORCID 0000-0002-4594-0915**

Antonchik Volodymyr, Chief Designer in Department of Pressure Dynamics Control in Rocks, M.S. Poliakov Institute of Geotechnical Mechanics of the National Academy of Sciences of Ukraine (IGTM of the NAS of Ukraine), Dnipro, Ukraine, Vladimir.antonchik1958@gmail.com.

Yanzhula Oleksii, Candidate of Technical Sciences (Ph.D.), Director of Directorate for Technical development, Capital Construction and investments, Limited Liability Company «METINVESTKHOLDING», Pokrovs'k, Ukraine, **ORCID 0009-0000-8906-0656**

Chorny Anatolii, Master of Science, Chief of Central headquarters of the SPMRS of Ukraine, Pavlograd, Ukraine.

Makarenko Roman, Master of Science, Deputy Chief Engineer of the Mine Administration Herojev of Space Mine Management", Pavlograd, Ukraine.

Belousov Oleh, Master of Science, Chief Engineer of "Pershotravensky" mine management DTEK "Pavlogradvugillya", Pavlograd, Ukraine.

Livak Oksana, Candidate of Technical Sciences (Ph.D.), Associate Professor in Department of Materials Science, Ukrainian State University of Science and Technologies (USUST), Dnipro, Ukraine, Roxiki@i.ua, **ORCID 0000-0002-5552-6531**

РОЗРОБКА НОВОЇ КОНСТРУКЦІЇ ВОГНЕПЕРЕКРИВАЧА ДЛЯ ГАСІННЯ ПОЖЕЖІ В ШАХТНИХ ГАЗОПРОВОДАХ

Мінєєв С., Антончик В., Янжула О., Чорний А., Макаренко Р., Білоусов О., Лівак О.

Анотація. В статті розглянуті питання виникнення, розповсюдження та гасіння пожеж в шахтних газопроводах для відводу метану при дегазації вугільного масиву та вміщуючих пласт порід. Розглянуто склад газової суміші в газопроводі, різні причини займання газів в газопроводі та особливості способів гасіння пожеж в шахтних газопроводах. Розглянуті пристрої які монтуються в різних газопроводах для гасіння вибухів і пожеж. Вказані основні недоліки цих пристроїв. Рекомендовані шляхи вдосконалення цих пристроїв.

Метою дослідження є розробка такого пристрою гасіння пожеж в шахтних газопроводах - вогнеперекривача шахтного газопроводу який гарантовано гасить фронт полум'я що рухається по газопроводу незалежно від його швидкості та напрямку руху.

В основу вдосконалення вогнеперекривача шахтного газопроводу поставлена задача створення таких перешкод, що гарантують згасання фронту полум'я в газопроводі шляхом не тільки розділення його на окремі потоки та пропускання через вузькі канали, а і змінення напрямку руху газового потоку пропускаючи його через лабіринт з двохступеневою пасткою вузьких каналів не збільшуючи при цьому газодинамічного опору пристрою під час його роботи в звичайному режимі відкачування газу вакуумними насосами. Пристрій повинен мати невеликі розміри з можливістю легко його встановлювати в шахті або на поверхні а також однаково ефективно гасити полум'я яке рухається як з поверхні так і в шахтних газопроводах.

Запропоноване нове технічне рішення в конструкції вогнеперекривача. Показаний ескізний проект нової конструкції вогнеперекривача. Наданий опис його конструкції і роботи. Показані переваги нової конструкції вогнеперекривача.

Даний розроблений вогнеперекривач для шахтного газопроводу має невеликі розміри та вагу, не потребує додаткового обладнання при обслугованні і може бути встановлений на довільній ділянці газопроводу, як в шахтних виробках так і на поверхні. Цей вогнеперекривач може виконувати гасіння фронту полум'я в обох напрямках та забезпечує незначний аеродинамічний спротив для руху газового потоку.

Ключові слова: вугільна шахта, дегазаційний газопровід, гасіння фронту полум'я, вибухі, вогнеперекривач, припливи повітря, концентрація метану.